

CrystalView Pro CAT5

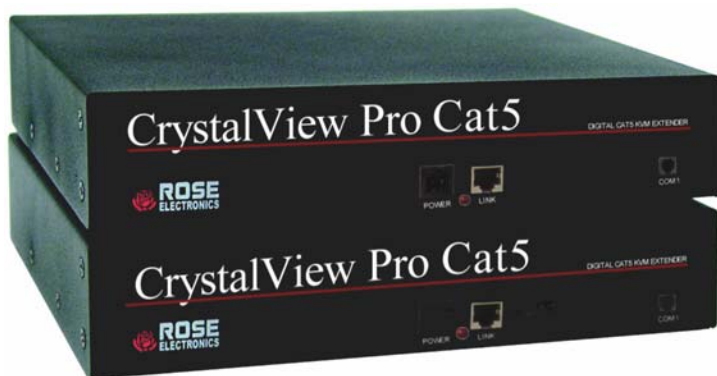

Digital CAT5 KVM extender

Extends keyboard, video, mouse, audio and serial signals up to 330 feet away

Supports DVI and VGA video at resolutions up to 1600 x 1200

Supports CAT5, CAT5e, and CAT6 cables

Single or Dual models

Easily adapted to your system

Features and Benefits

- Supports:
 - DVI and VGA video modes
 - PS/2 keyboards and mice
- Extend a KVM station from a CPU using:
 - CAT5 cable – 330 feet
 - CAT5e cable – 330 feet
 - CAT6 cable – 330 feet
- Video resolutions up to 1600 x 1200
- Dual version available
- Serial and audio options
- Compatible with Rose Electronics KVM switches such as ServeView Pro, UltraView Pro, and UltraMatrix.
- Compatible with windows, windows NT, OS/2, UNIX, Linux, and other operating systems
- Fully automatic KVM sharing (Local access models)
- Digital OSD setup menu
- 1U Rackmount kits – 19", 23", or 24"
- Available in a 10-unit rack (Transmitters or receivers)

The CrystalView™ Pro CAT5 Advantage

The CrystalView Pro CAT5 is the KVM extender of choice for businesses that need to extend and operate a computer, server, or KVM switch from a great distance. The CrystalView Pro CAT5 makes this possible by the use of standard CAT5 cable. You can fully operate and control a computer or server from as far away as 330 feet using standard CAT5 cable.

The CrystalView Pro CAT5 supports both DVI video as well as analog VGA video. All combinations of DVI and VGA video cards and monitors are supported.

The Serial/Audio model allows stereo audio to be transmitted in either direction across the CAT5 link simultaneously. Many serial devices like a Touchscreen can plug directly into the serial port on the Remote Unit. The OSD features make it easy to adjust all the necessary device parameters, color, brightness, contrast, and saturation. RGB color compensation is performed from the remote unit. This adjusts each color to achieve the best image and compensate for differences in cables, patch panels, and connectors.

The modular architecture makes the CrystalView Pro CAT5 easily adapted to your system.

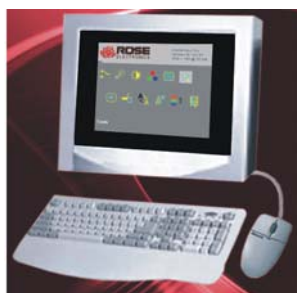

On-Screen Display

Typical Application

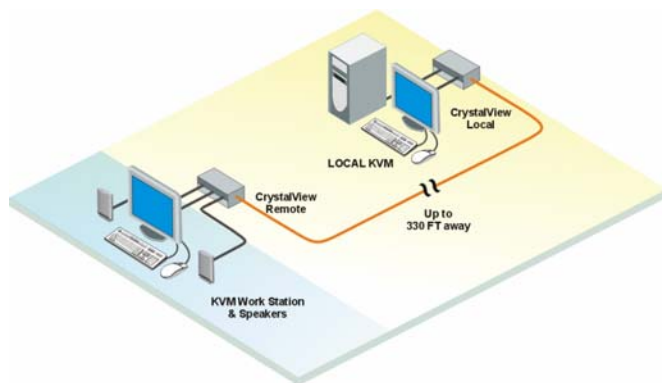

Digitally access a computer from two locations, one is local, the other is 330 feet away

CrystalView Pro CAT5 basics The CrystalView Pro CAT5 system consists of a transmitter that connects to a PC, server, or KVM switch and a receiver that connects to a keyboard, monitor, and mouse or a KVM switch. The transmitter and receiver units are connected together with up to 330 feet of standard CAT5 cable.

The ideal way to apply the CrystalView Pro CAT5 is to connect the transmitter to a Rose Electronics KVM switch. Expanding the switch allows the receiver to access up to 1,000 computers or servers. The Rose Electronics KVM switch can be connected between the transmitter and computers, the KVM station and the receiver unit, or both.

Models The CrystalView Pro CAT5 is available in a PC model. The dual version allows for a second KVM station next to the PCs, providing operation from the transmitter or the receiver unit. A rack version, containing 10 transmitters or receivers is also available.

On-screen display All models offer a digital on-screen display for setup and configuring the unit for DVI or VGA.

Installation Installing the CrystalView Pro CAT5 units is as easy as connecting the KVM station to the receiver, connecting the CPU to the transmitter, and connecting the transmitter to the receiver with CAT5 cable.

Keyboard and Mouse emulation The CrystalView Pro CAT5 uses a microprocessor to emulate the keyboard and mouse.

Rack Assembly The CrystalView Pro CAT5 can be ordered in a 10-unit rack assembly with several options available.

Part Numbers

CRK-2DTPPDVI

Dual Digital CAT5 KVM extender (Transmitter and Receiver)
Male to VGA HD15F Adapter
Audio and Serial option
Rack mount kits
(xx = 19", 23", or 24")

ACC-DVIVF
/AUD
RM-UMxx

Specifications

Dimensions	5.6W x 6.7D x 1.5H (in.) 142W x 169D x 41 (mm)
Weight	2.2 lbs / 1.0 kg (each unit)
Operating Temp	10°C – 45°C / 50°F – 113°F
Humidity	80% max, non-condensing
Resolution	1600 x 1200
Connectors	Video – DVI - I PC keyboard – MiniDIN6 PC mouse – MiniDIN6 Power – 4-pin square Program (Com 1) – RJ11
Power	90-240 VAC to 6.0 VDC 200 ma Local interface = 8 W Remote interface = 9.5W
Max distance	330' CAT5 stranded cable 200' CAT5 solid cable
Indicators (LEDs)	Front panel – Communication Rear panel – Power / Link / Video CE
Approvals	CE



Rearview, CrystalView Pro digital CAT5 KVM extender with serial and audio options